

为什么选择利优刀具研磨机? 因为我们能为客户创造**6**大价值!

- ①免去将刀具送到修磨公司的开支
- ②免去雇佣磨刀师傅的开支
- ③大大缩短磨刀花费的时间
- ④杜绝磨刀导致的工伤事故
- ⑤提升加工效率和质量
- ⑥降低刀具购买支出达70%以上!

Why choosing our products?

Because we can bring you the following benefits.

- Much saving from purchasing new tools.
- Saving from dull or bad tools re-sharpening outside.
- Saving from hiring skilled worker for re-sharpening.
- Saving from re-sharpening time shortened.
- No injure during re-sharpening process.
- Increase of processing efficiency and quality.

利优精机
LIYOU

LIYOUONE®
利优机床

国家高新技术企业



专利技术, 缔造品质传奇!

江苏利优机床有限公司

Jiangsu Liyou Machine Tool Co. Ltd.

泰州市利优精密机械有限公司

Taizhou Liyou Precision Machinery Co., Ltd

地址: 江苏省泰州市海陵区城北物流园区北星北路1号
Add: No.1, North Beixing Road, North Logistics Park,
Hailing District, Taizhou City, Jiangsu Province
Tel: (86)0523-86593628 Fax: (86)0523-86593638
E-mail: resharpen@liyouone.com
Http: www.liyouone.com



利优官网



微信平台

利优刀具修磨中心, 承接刀具修磨/刀具定制
Liyou Tool Grinding Center, Undertake Tool Grinding / Tool Customization

-利优机床, 刀具生产/研磨利器-



江苏利优机床有限公司
Jiangsu Liyou Machine Tool Co. Ltd.
泰州市利优精密机械有限公司
Taizhou Liyou Precision Machinery Co., Ltd

关于我们

利优是一家技术领先的刀具自动化生产设备、刀具研磨设备及同类精密机械设备的专业制造商，同时成立了多轴联动刀具自动化生产和研磨的软件开发中心，并拥有多项软件著作权，利优软件让刀具生产和研磨更加简单、便捷、高效。作为一家富有创新精神的企业，公司打造了集研发、设计、生产、销售和售后服务为一体的综合性运营平台。致力于以高附加值的产品和服务，帮助客户实现提升机械加工效率并降低刀具使用成本的目的。

目前公司拥有数控工具磨床、万能工具磨床、铣刀研磨机、球刀研磨机、钻头研磨机、铣刀钻头复合研磨机、倒角机等具有自主知识产权的系列产品，并拥有配备先进加工设备的现代化生产基地，可年产上述设备上万台。凭借产品操作便捷、研磨精度高、质量可靠性强、售后服务完善等优势，公司产品得到德国、俄罗斯、马来西亚、日本、约旦、以色列、印尼、印度、新加坡、台湾、香港等国家和地区客户的广泛认可。

在不断变化的环境和快速的发展过程中，利优精机始终坚持以客户价值最大化为经营导向，不懈追求“诚信、务实、创新、卓越”企业价值观，以持续增强技术创新能力为手段，不断满足并超越客户期望。

未来，公司将继续秉承自主创新理念，坚定不移的走国际化道路，为成为全球最专业的刀具精密研磨设备供应商而持续奋斗。

About Us

Liyou is a leading manufacture of tool automation production equipment, tool grinding equipment and similar precision machinery equipment. It also establishes a software development center for automated production and grinding of multi-axis linkage tools, and has a number of software copyrights. Liyou software makes tool production and grinding easier, more convenient and more efficient. As an innovative enterprise, Liyou has established a comprehensive operation platform which integrates R&D, design, production, sales and after-sales service. Liyou is committed to helping customers improve machining efficiency and reduce bit tools cost with high value-added products and services.

At present, Liyou has series of products with independent intellectual property rights such as CNC Tool Grinding Machine, Universal Tools Grinding Machine, End mill Re-sharpener, Ball end mill Re-sharpener, Drill Re-sharpener, End Mill & Drill Complex Re-sharpening Machine, Chamfering Machine, etc. What's more, Liyou has a modern production base and annual output thousands of above products. With the advantages of convenience, high precision, reliability, perfect after-sales service, our products have been widely used in Germany, Russia, Malaysia, Japan, Jordan, Israel, Indonesia, India, Singapore, Taiwan, Hong Kong and etc.

In a constantly changing environment where enterprise is rapidly developing, Liyou always adhere the spirit of "customer value maximization", unremitting pursuit the corporate value of "integrity, pragmatism, innovation, excellence", and continuously strengthen technological innovation to meet and exceed customer expectations.

In the future, Liyou will continually adhere to the concept of independent innovation, unswervingly pursue internationalization, and strive to become the world's most professional precision tool grinding equipment supplier.

企业文化 Enterprise Culture

企业精神 Enterprise Spirit

诚信、务实、创新、卓越

Integrity, Pragmatism, Innovation, Excellence

企业愿景 Vision

成为全球专业的刀具精密研磨设备供应商。

We strive to be the world's most professional precision tool grinding equipment supplier.

企业使命 Mission

以实现客户价值最大化为导向，不断坚持技术创新，在不断满足并超越客户期望的过程中，实现员工、社会和股东价值最大化。

Oriented to maximize customer value, continuously strengthen technological innovation to meet and exceed customer expectations, maximize employees, society and shareholder value.

经营理念 Operation Principle

以科技领先和质量可靠为生命线，始终坚持相关利益方多赢的经营宗旨。

Use leading technology and reliable quality as the lifeline, and always adhere to the stakeholder win-win business situation.

营销网络 Marketing Network

利优产品已经覆盖到亚洲、欧洲、美洲、大洋洲的30多个国家和地区。

Our products have be distributed to over 30 countries.

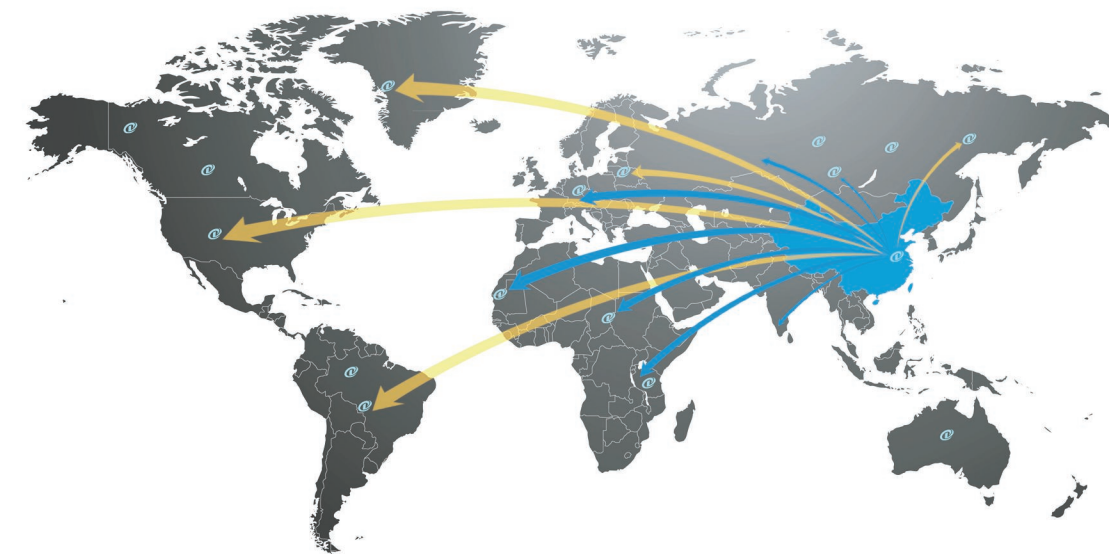

U.S.A./Canada / German / England / France / Italia / Holland / Denmark / Russia / Ukraine / Turkey
Japan / Korea / India / Singapore / Thailand / Malaysia / Philippines / Vietnam / Indonesia / Iran / Egypt / Australia /

五轴数控工具磨床 (刀具生产、刀具再研磨的理想选择)

5-AXIS CNC TOOL GRINDING MACHINE (The best choice for tool&cutter produce and resharpen)

型号Model:
CTG-520/526



产品功能及特点

• PRODUCT ADVANTAGES •

- 直观的 3D 图形界面, 使操作非常简单, 可以生产、研磨铣刀和钻头等各类刀具, 无需经验即可轻松操作, 可根据客户的需求, 修改参数, 生产和研磨出需要的理想刀具。
 - 自主研发的可实现 5 轴联动的操作系统。
 - 可根据客户需求, 定制特殊刀具的软件功能, 满足客户的需求。
 - 软件升级简单方便, 只需通过 USB 接口, 即可轻松享有免费的升级服务。
 - 大大降低用于生产和修磨刀具的设备投入成本, 超低的投入能给你带来高额的回报!
- 1.Intuitive 3D graphical interface, makes it easy to operate. Can produce and grind end mill, drill and other kinds of tools, can easily be operated without experience. Can modify the parameter according to customer's demand, produce and grind the ideal tools.
- 2.Independent developed five-axis linkage operation system.
- 3.Customer-made software functions for specific tool, meet different needs.
- 4.Software upgrades is simple,easily enjoy free upgrade service through USB.
- 5.Greatly reduce the cost of the equipment for producing and re-sharpening tools. Ultra low input can bring you with high return!

无需请专业磨刀师傅

no need to hire professional tool grinding worker

无需请专业编程师傅

no need to hire professional programming worker

一人可操作多台机器

one person can operate multiple machines



主要功能 Main function	直径范围 Applicable	CTG-520 1~20mm CTG-526 1~25mm
	刀具种类 Main function	铣刀、钻头、球头铣刀、丝锥 等刀具 End mill, Drill, Ball end mill cutter, tap Cutter...
	刀具长度 Tools length	330mm
	刀具最大刃长 Longest blade	150mm
砂轮主轴 Grinding wheel spindle	主轴类型 Spindle type	电主轴 electrical spindle
	功率 Motor	4KW
	最大转速 Max. RPM	8000
	砂轮最大线速度 Max peripheral speed of grinding wheel	36m/S
	砂轮杆类型 Grinding wheel shaft type	BT30
	砂轮孔径 Grinding wheel hole diameter	31.75mm
	砂轮片数 Grinding wheel number	4
设备参数 Product Parameter	电源 Power	380V
	机器尺寸 Dimensions	1650*1550*2000
	机器重量 Weight	1700KG
	位置检测 Tools Detection	高精度接触式3D探针检测 High accuracy contact 3D probe detection
	导轨油 Rail oil	(ISO VG68)
控制轴 Control shaft	控制电机类型: 伺服电机x 5轴 Control motor type: servo motor x 5 axis	行程 Route
	X轴	400mm
	Y轴	300mm
	Z轴	160mm
	C轴	-45° ~ 190°
	A轴	∞
精度 Accuracy	定位精度 Positioning accuracy	0.005mm
	重复定位精度 Repeated positioning accuracy	0.003mm
	A轴孔内锥度跳动 A axis hole inner taper beat	0.002mm

五轴数控工具磨床 (刀具生产、刀具再研磨的理想选择)

5-AXIS CNC TOOL GRINDING MACHINE (The best choice for tool&cutter produce and resharpen)

型号Model:

CTG-520s/526s

CTG-520s气动/526s气动

Pneumatic Style Pneumatic Style



自主研发5轴数控软件，傻瓜式操作，软件免费升级，可以根据客户要求定制软件。

Independent research and development of 5-axis CNC software, foolish operation, free software upgrade, can be customized according to customer requirements

型号 Model	CTG-520s	CTG-526s	CTG-520s气动 Pneumatic Style	CTG-526s气动 Pneumatic Style
直径范围 Applicable	1~20mm	1~26mm	1~20mm	1~25mm
主要功能 Main function	铣刀、钻头、球头铣刀、丝锥 等刀具 End mill, Drill, Ball end mill cutter, tap Cutter....			
刀具种类 Main function	铣刀、钻头、球头铣刀、丝锥 等刀具 End mill, Drill, Ball end mill cutter, tap Cutter....			
刀具长度 Tools length	330mm	330mm	220mm	220mm
刀具最大刃长 Longest blade	90mm			
砂轮主轴 Grinding wheel spindle	电主轴 electrical spindle			
功率 Motor	2KW			
最大转速 Max. RPM	6000			
砂轮最大线速度 Max peripheral speed of grinding wheel	30m/S			
砂轮孔径 Grinding wheel hole diameter	31.75mm			
电源 Power	220V			
机器尺寸 Dimensions	1300*1200*1720			
机器重量 Weight	760KG			
位置检测 Tools Detection	高精度接触式3D探针检测 High accuracy contact 3D probe detection			
导轨油 Rail oil	(ISO VG68)			
设备参数 Product Parameter	控制电机类型: 伺服电机x 5轴 Control motor type: servo motor x 5 axis			
控制轴 Control shaft	行程 Route			
	X轴	300mm		
	Y轴	160mm		
	Z轴	160mm		
	C轴	-45°~190°		
A轴	∞			

四轴数控枪钻工具磨床

4-AXIS CNC GUN DRILL GRINDING MACHINE

型号Model:

GD-20/26



NEW PRODUCT GUNDRILL
新品上市枪钻
枪钻长度不受限制

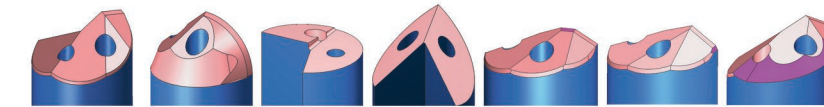

型号 Model	GD-20	GD-26
刀具种类 Main function	标准枪钻、球头枪钻..... Standard gun drill, ball head gun drill....	
直径范围 Applicable	Φ1mm~Φ20mm	Φ1mm~Φ25mm
刀具长度 Tools length	不限 unlimited	
刀具最大刃长 Longest blade	不限 unlimited	
刀具材质 Material	硬质合金/钨钢(carbide)/高速钢 (HSS)	
主轴电机功率 Spindle motor	1.1KW	
速度 Speed	500~6000	
砂轮最大线速度 Max peripheral speed of grinding wheel	36m/S	
电源 Power	220V 3KW 50/60HZ	
机器尺寸 Dimensions	1200*1000*1600	
机器重量 Weight	650KG	
位置检测 Tools Detection	高精度接触式探针检测 Contact probe detection with high precision	
切削油 Cutting oil	非水溶性研磨油 Water-insoluble grinding oil	
导轨油 Rail oil	(ISO VG68)	
切削油泵 Cutting oil pump	输出最大流量 24L/M Maximum output flow	
驱动方式 Drive mode	X/Y轴:滚珠丝杠直接传动 X/Y:Ball screw direct drive	C轴:谐波减速器传动 C:Harmonic reducer drive
控制轴 Control shaft	伺服电机x 4轴 servo motor * 4 axes	
X轴	行程 Route	
	130mm	
	位置控制分辨率 Position control resolution	
	0.001mm	
	Y轴	
210mm		
0.002mm		
C轴		
-5°~100°		
0.001°		
A轴		
∞		
0.01°		

四轴数控工具磨床系列 (刀具生产、刀具再研磨的理想选择)

4-AXIS CNC TOOL GRINDING MACHINE (The best choice for tool&cutter produce and resharpen)

型号Model:

CTG-20/26

CTG-20气动/26气动



气动款/Pneumatic Style

自带刀具切断功能

With tool cutting function

无需请专业磨刀师傅

no need to hire professional tool grinding worker

无需请专业编程师傅

no need to hire professional programming worker

一人可操作多台机器

one person can operate multiple machines



产品功能及特点

PRODUCT ADVANTAGES

- 1.直观的 3D 图形界面,使操作非常简单,无需经验即可轻松操作,可根据客户的需求,修改参数,研磨出需要的理想刀具。
 - 2.自主研发的可实现 4 轴联动的操作系统。
 - 3.可根据客户需求,定制特殊刀具的软件功能,满足客户的需求。
 - 4.软件升级简单方便,只需通过 USB 接口,即可轻松享有免费的升级服务。
 - 5.可配合开槽机,即可生产铣刀和钻头,大大降低生产铣刀和钻头的设备投入成本,超低的投入能给你带来高额的回报!
- 1.3D graphics interface, easy to use, parameters can be modified according to the customer's requirements.
 - 2.Independent developed four-axis linkage operation system.
 - 3.Customer-made software functions for specific tool, meet different needs.
 - 4.Software upgrades is simple,easily enjoy free upgrade service through USB.
 - 5.Cooperate with slot machine,this machine can produce milling cutter and drills which can reduce the equipment investment.

型号 Model	CTG-20	CTG-26	CTG-20气动款 Pneumatic Style	CTG-26气动款 Pneumatic Style
刀具种类 Main function	铣刀、钻头、球头铣刀、丝锥、雕刻刀、枪钻、T型刀、小镗刀等刀具 End mill, Drill, Ball end mill cutter, tap, Graver, Small Boring Cutter...			
直径范围 Applicable	Φ1mm~Φ20mm	Φ1mm~Φ26mm	Φ1mm~Φ20mm	Φ1mm~Φ25mm
刀具长度 Tools length	35 ~ 250mm	35 ~ 250mm	(Φ1mm~Φ14mm) 35~170mm (Φ14mm~Φ20mm) 35~110mm	(Φ1mm~Φ19.5mm) 35~230mm (Φ19.5mm~Φ25mm) 35~110mm
刀具最大刃长 Longest blade	85mm			
刀具材质 Material	硬质合金/钨钢(carbide)/高速钢 (HSS)			
主轴电机功率 Spindle motor	1KW			
速度 Speed	1000 ~ 6000			
砂轮最大线速度 Max peripheral speed of grinding wheel	36m/S			
电源 Power	220V 1.5KW 50/60HZ			
机器尺寸 Dimensions	880*900*1560 1240*1050*1560(气动款/Pneumatic Style)			
机器重量 Weight	350KG 430KG(气动款/Pneumatic Style)			
位置检测 Tools Detection	高精度接触式探针检测 Contact probe detection with high precision			
切削油 Cutting oil	非水溶性研磨油 Water-insoluble grinding oil			
导轨油 Rail oil	(ISO VG68)			
切削油油泵 Cutting oil pump	输出最大流量 24L/M Maximum output flow			
驱动方式 Drive mode	X/Y轴:滚珠丝杠直接传动 X/Y:Ball screw direct drive	C轴:谐波减速器传动 C:Harmonic reducer drive	A轴:同步带轮直接传动 A:synchronous belt direct drive	
控制轴 Control shaft	步进电机× 4轴 Stepping motor for 4 axis			
	行程 Route			位置控制分辨率 Position control resolution
X轴	300mm / 130mm			0.002mm
Y轴	130mm			0.002mm
C轴	-5°~180°			0.005°
A轴	∞			0.02°

四轴数控工具磨床 (刀具生产、刀具再研磨的理想选择)

4-AXIS CNC TOOL GRINDING MACHINE (The best choice for tool&cutter produce and resharpen)

可研磨几十种刀具 可根据客户的需求

订制特殊刀具的修磨、制造功能，无需改进设备，只需升级软件即可。

Available for dozens of grinding tools The function can be made according to customer needs, only need to update software.

新增钝化功能，刀具研磨后，刀具直接自动钝化，无需额外购买钝化设备，提高刀具使用寿命。

Newly add honing function, after tool re-sharpening, tool direct automatically honing, no need purchase honing equipment, increase tool life

新增刀片修磨功能

New function of blade re-sharpening

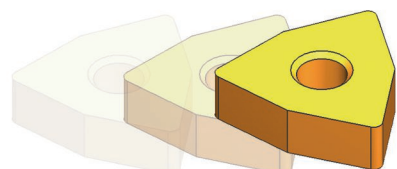

球头铣刀

Ball end mill cutter:

主要功能 Main function 研磨球头铣刀切削刃、开槽、避空位、棒料制作直槽球刀
Grind the cutting edge of ball end mill cutter, open slot, avoid vacancy. Use bar to make direct flute ball end mill



刃数 Edge number 2

阶梯钻头

Step drill

主要功能 Main function 研磨阶梯钻头的底刃的切削刃、横刃、阶梯的切削刃、侧刃外圆和避空位、标准钻头改阶梯钻头
Grind cutting edge of the end cutting edge, chisel edge, cutting edge of the step, side edge outer circle and avoid vacancy of the step drill. Standard drill change into step drill



刃数 Edge number 2, 3

丝锥

Tap

主要功能 Main function 可研磨直刃丝锥和螺旋丝锥前端导向刃、端面、前端锥面
Grind front guide blade, end and front cone of direct blade tap&screw tap

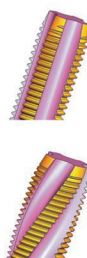

沟槽数 Flutes 2, 3, 4

雕刻刀

Graver

主要功能 Main function 可用圆棒直接制作雕刻刀、圆鼻雕刻刀、球头雕刻刀、单刃铣刀、三角形雕刻刀、多边形雕刻刀。
Can use round bar to make graver, round nose graver, ball head graver, single flute end mill, triangle graver and so on.

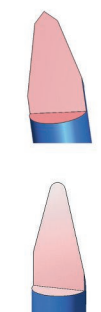

T型刀

T type knife

主要功能 Main function 研磨T型刀的底刃、侧刃、内侧台阶端面和避空位
Grind the end cutting edge, inside side edge, step end surface and avoid vacancy of the T-type knife

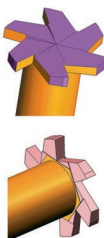

刃数 Edge number 3, 4, 5, 6

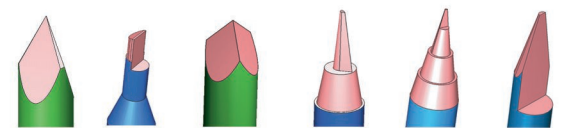

铣刀

End mill

主要功能 Main function 研磨铣刀底刃、等分、不等分、不等角、开槽、侧刃、平底R角、C角铣刀
Grind end mill, Equal, Unequal, Unequal Angleslotting, side blade, R angle&C angle mill

刃数 Edge number 2, 3, 4, 5



钻头

Drill

主要功能 Main function 研磨平面和锥面钻头的切削刃、横刃、横刃R角、切削刃倒C角、切刃R角、切削刃C角
Grind the cutting edge, chisel edge, chisel edge R angle, cutting edge C angle of plate&cone drills

钻头刃数 Drill flutes 2, 3



铰刀

Reamer

主要功能 Main function 可研磨直刃铰刀和螺旋铰刀导向刃、侧刃、端面、可修磨阶梯铰刀
Grind guide blade, side blade and end blade of direct blade&screw reamer, can re-sharpen step reamer.

沟槽数 Groove 4, 6, 8

燕尾槽铣刀

Swallow-tail flute end mill

主要功能 Main function 修磨燕尾槽铣刀的底刃和侧刃
re-sharpen bottom edge and side edge of swallow-tail flute end mill

刃数 Edge number 2-8

半圆刀

Semi-circle tool

主要功能 Main function 可用棒料制作半圆刀和修磨半圆刀
can use bar to make semi-circle tool and re-sharpen semi-circle tool

R后角 R relief angle 1° ~ 20°

多边形、腰形销、台阶圆柱、圆锥面、阶梯外圆

Polygon, Waist-shape Pin, Step Cylinder, Conical Surface, Step Outer Circle

主要功能：棒料制作多边形、腰形销、台阶圆柱、圆锥面、阶梯外圆等
Main Functions: use bar to make polygon, waist-shape pin, step cylinder, conical surface and step outer circle etc.

平底C角、大R角铣刀

Flat C angle, big R angle cutter

主要功能 Main function 可研磨C角、大R角铣刀的切削刃、开槽
Can grind C angle, cutting edge of big R angle cutter, open slot

刃数 Edge number 2

后角 Relief angle 1° ~ 15°

第二后角 Second relief angle 12° ~ 30°

第三后角 Third relief angle 20° ~ 50°

倒角刀

Chamfering

主要功能 Main function 可用棒料制作倒角刀，可以修磨底刃、开槽、切削刃、锥形倒角刀。
Can use bar to make counter sink, can re-sharpen bottom edge, gash, cutting edge, cone shape counter sink.

刃数 Edge number 2, 3, 4

小镗刀

Small Boring Cutter

主要功能 Main function 可用棒料制作镗刀，可以修磨镗刀
Can use bar to make boring cutter, can re-sharpen boring cutter.

阶梯扁钻头

Step flat drill

主要功能 Main function 可用棒料自作左切、右切削阶梯扁钻，可修磨阶梯扁钻的各阶梯。
can use bar to make left cut and right cut step flat drill, can re-sharpen every step of step flat drill.

阶梯数 Step number 5

枪钻

Gun drill

主要功能 Main function 可生产和修磨钻尖各后角、倒角，以及生产和修磨枪钻V型
can make drill tip every relief angle and chamfer, make and re-sharpen gun drill V shape

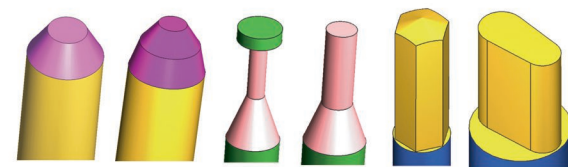

五轴数控工具磨床 (虎钳、铲刀生产、修磨的理想选择)

5-AXIS CNC TOOL GRINDING MACHINE (Ideal of manufacture and re-sharpening of vice and blade)

型号 Model:
CTG-520/526

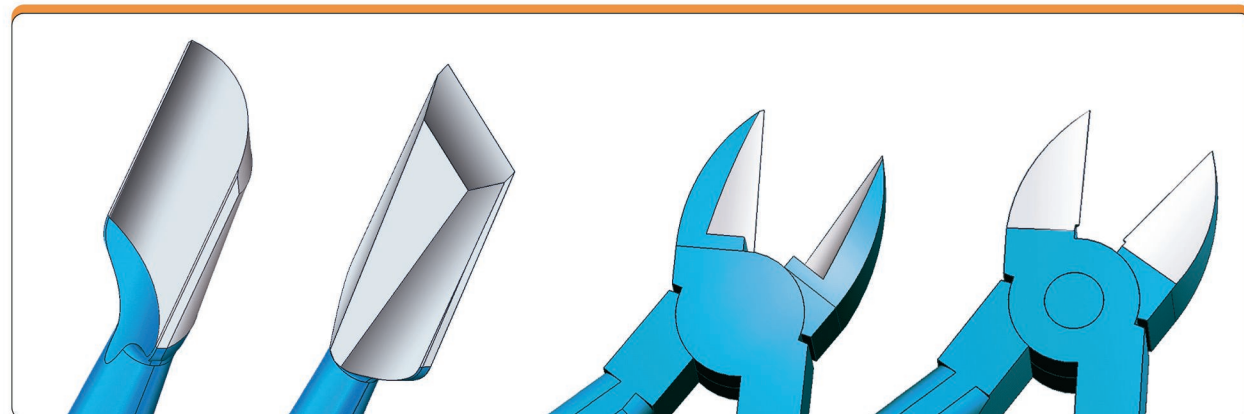
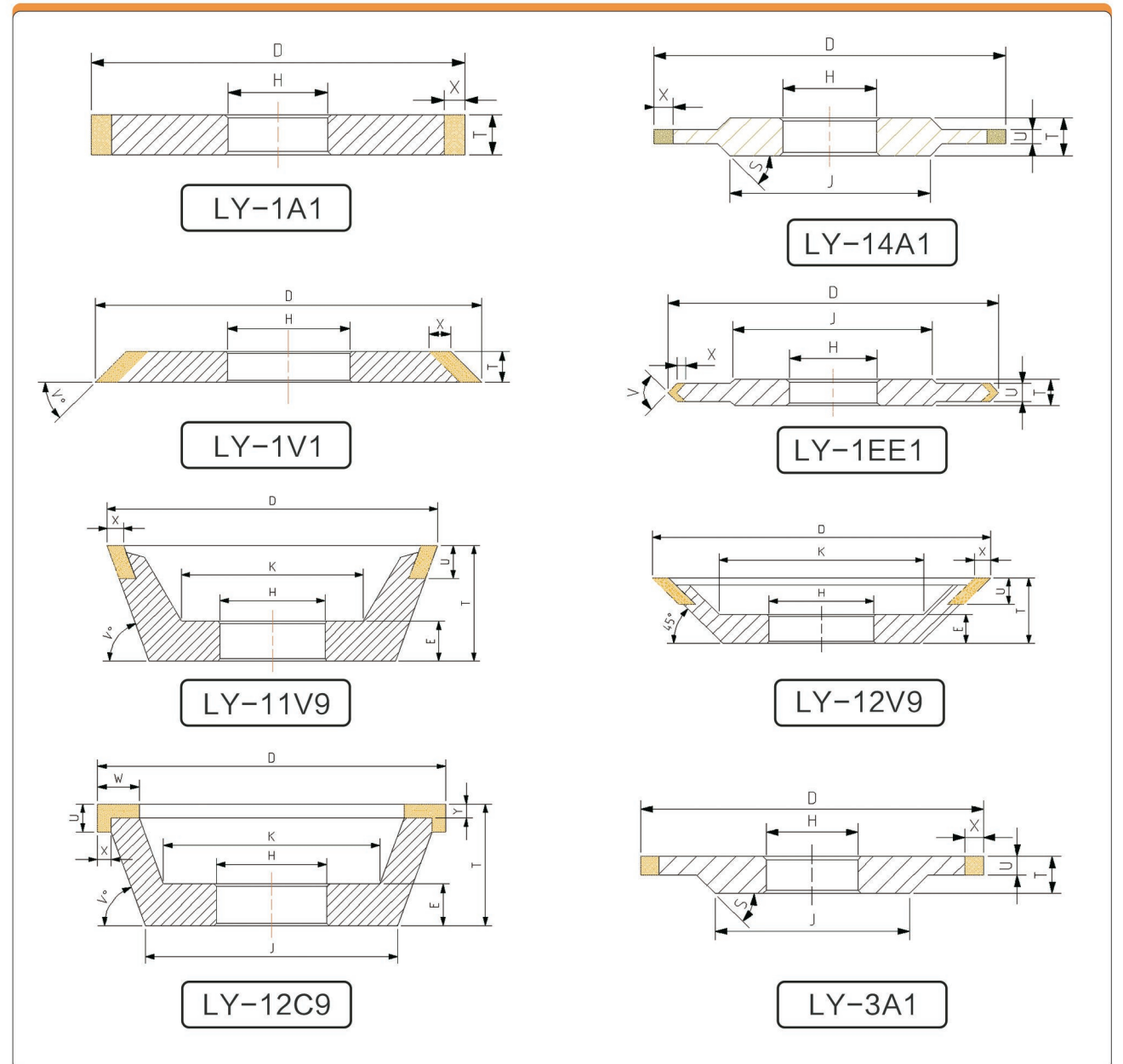

铲刀 blade

虎钳 vice

利优数控工具磨床砂轮适用于其它各类品牌数控工具磨床

The grinding wheels of Liyou CNC Tool Grinding Machine are suitable for the other brand CNC Tool Grinding Machines.

进口品质 经济实惠

Imported Quality, Economical and Practical

高效 锋利 耐用

High Efficiency, Sharp, Durable

铣刀钻头复合研磨机系列 End Mill & Drill Complex Re-sharpening Machine

型号Model :
ED-12/12A/12H/20/20H



产品功能及特点
PRODUCT ADVANTAGES

●铣刀/End mill

1. 可研磨2刃、3刃、4刃硬质合金及高速钢端铣刀；
2. 研磨铣刀部位为刀刃角、前斜角和后斜角；
3. 一片砂轮即可完成不同刃数、不同直径的铣刀研磨；
4. 操作方便，任何人都能在1分钟内完成研磨；
5. 研磨后铣刀标准和新刀保持一致，刀刃等高精度在0.01mm以内；
6. 可根据切削材料不同，调整刀尖锋利程度，提升铣刀寿命和切削效率、加工精度。

1. Applicable to (2\3\4-flute) tungsten carbide and high-speed steel end mill.
2. Grind rear inclined angle, blade edge and front inclined angle.
3. For different end mill grinding, no need to change grinding wheel.
4. Easy to handle, grind one piece need no more than one minute.
5. High precision(0.01mm), normatively re-sharpening.
6. Mill cutting edge can be adjusted suitable for materials to be processed.

●钻头/Drill

1. 可研磨直柄和锥柄标准麻花钻头；
2. 可研磨硬质合金及高速钢麻花钻头；
3. 研磨钻头长短不限；

1. Can grind standard twist drill of direct shank and cone shank
2. Applicable to tungsten carbide and high-speed steel drills re-sharpening.
3. Length of drill to be grinded has no limitation.

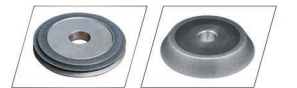

砂轮说明：
SDC砂轮专用于研磨硬质合金刀具，CBN砂轮专用于研磨高速钢刀具

Grinding wheel: SDC wheels used for tungsten carbide tools, CBN wheels used for high-speed steel tools.



设备参数 Product Parameter

型号 Model	适用直径 Applicable diameters	适用刃数 Applicable flutes	铣刀底刃研磨角度 Axial angles	砂轮 Grinding wheel	电源 Power	先端角(顶角)研磨范围 Grinding scope of the apex angle	转速 Rated speed	设备外型尺寸 Outer dimensions	设备重量/功率 Weight/Power	标准附件 Normal accessories
ED-12 ED-12H (带精磨with fine grinding)	铣刀/End mill φ2~φ12mm 钻头/Drill φ3~φ20mm	2刃、3刃、4刃 2flutes、3flutes、4flutes 标准麻花钻Twist drills	刀刃角6° Secondary clearance angle 6° 前斜角20° Primary relief angle 20° 后斜角30° End gash angle 30°	E12SDC(or CBN) EDCBN(or SDC)	220V±10%AC	90°~140°	6000 rpm	320x 350 x 330(mm)	18KG /300W	夹套 7 个, 2 刃夹套固定套 8 个, 3 刃夹套固定套 8 个, 4 刃夹套固定套 8 个, 工具盒 1 个, 六角扳手 2 支, 控制器 1 个, 夹头组 1 组 Collet*7pcs, 2 flutes holder*8pcs, 3 flutes holder*8pcs, 4 flutes holder*8pcs, case*1pcs, Hexagon wrench*2pcs, controller*1pcs, Chuck group*1 Group
ED-12A	铣刀/End mill φ2~φ12mm 钻头/Drill φ3~φ20mm	2刃、3刃、4刃 2flutes、3flutes、4flutes 标准麻花钻Twist drills	刀刃角8° Secondary clearance angle 8° 前斜角22° Primary relief angle 22° 后斜角30° End gash angle 30°	E12SDCA(or CBN) EDCBN(or SDC)	220V±10%AC	90°~140°	6000 rpm	320x 350 x 330(mm)	18KG /300W	夹套 7 个, 2 刃夹套固定套 8 个, 3 刃夹套固定套 8 个, 4 刃夹套固定套 8 个, 工具盒 1 个, 六角扳手 2 支, 夹头组 1 组, 控制器 1 个, 垫圈 6 个, 专用夹套 1 只 Collet*7pcs, 2 flutes holder*8pcs, 3 flutes holder*8pcs, 4 flutes holder*8pcs, case*1pcs, Hexagon wrench*2pcs, Chuck group*1 Group, controller*1pcs Gaskets*6pcs, square flutes holder*1pcs
ED-20 ED-20H (带精磨with fine grinding)	铣刀/End mill φ4~φ20mm 钻头/Drill φ3~φ20mm	2刃、3刃、4刃 2flutes、3flutes、4flutes 标准麻花钻Twist drills	刀刃角6° Secondary clearance angle 6° 前斜角20° Primary relief angle 20° 后斜角30° End gash angle 30°	E20SDC(or CBN) EDCBN(or SDC)	220V±10%AC	90°~140°	6000 rpm	370x 350 x 380(mm)	26KG /600W	夹套 8 个, 2 刃夹套固定套 8 个, 3 刃夹套固定套 8 个, 4 刃夹套固定套 8 个, 工具盒 1 个, 六角扳手 2 支, 控制器 1 个, 夹头组 1 组 Collet*8pcs, 2 flutes holder*8pcs, 3 flutes holder*8pcs, 4 flutes holder*8pcs, case*1pcs, Hexagon wrench*2pcs, controller*1pcs

铣刀研磨机系列 End mill Re-sharpening Machine



专有技术，高精度，高效率！
Patented products, high precision, high efficiency
专利号(Patent NO): ZL200920130566.0,
ZL200920130420.6, ZL200920131381.1



利优端铣刀研磨机和传统端铣刀研磨机的区别
Our advantages

对比项目	利优端铣刀研磨机	传统端铣刀研磨机
对刀装置	简单快捷，刀刃清晰可见，对刀方便。	看不到刀刃，无法根据磨损情况调整刀刃方向。
研磨精度	研磨精度在0.01mm以内，完全达到新刀标准。	研磨精度较低，影响加工效率和效果。
研磨后刀尖锋利程度	可以根据加工材料不同，调整研磨后的刀尖的锋利程度，提升寿命和切削效率、加工精度。	无法调整研磨后的刀尖锋利程度。
研磨后铣刀寿命	研磨后刃宽与新刀一致、刀尖等高，使用寿命长。	不同直径铣刀研磨后刃宽都一样，刀尖高度偏差较大。
研磨效率	一片砂轮可实现不同规格刀具研磨，研磨效率高。	需更换砂轮来实现不同规格刀具研磨，研磨效率低。
配件可靠性	专用无刷电机保修两年，实际使用寿命可达2万小时。夹套及研磨口均采用40Cr材料淬火后精加工，正常后期不需更换。	电机使用寿命一般不超过2千小时，购买机器1-2年需更换新电机。采用弹簧夹头，易生锈和损坏，后期需另行购买。

铣刀研磨机系列 End mill Re-sharpening Machine

优化的整体结构
Optimized structure design



高精度砂轮及研磨口设计
High precision grinding wheel and grinding structure

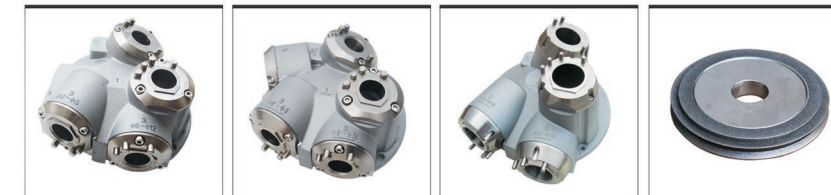

砂轮说明：SDC砂轮专用于研磨硬质合金刀具，CBN砂轮专用于研磨高速钢刀具
Grinding wheel: SDC wheels used for tungsten carbide tools, CBN wheels used for high-speed steel tools.

独特高效对刀装置
Unique mill edge adjustment device



精密的配套夹具
Precise holder fixture



研磨步骤
Re-sharpening operation steps



铣刀研磨机系列 End mill Re-sharpening Machine

型号Model:
ERM-12/20/32



砂轮说明:

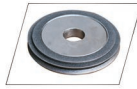

SDC砂轮专用于研磨硬质合金刀具, CBN砂轮专用于研磨高速钢刀具

Grinding wheel: SDC wheels used for tungsten carbide tools, CBN wheels used for high-speed steel tools.

产品功能及特点
PRODUCT ADVANTAGES

1. 可研磨2刃、3刃、4刃硬质合金及高速钢端铣刀;
2. 研磨铣刀部位为刀刃角、前斜角和后斜角;
3. 一片砂轮即可完成不同刃数、不同直径的铣刀研磨;
4. 操作方便, 任何人都能在1分钟内完成研磨;
5. 研磨后铣刀标准和新刀保持一致, 刀刃等高精度在0.01mm以内;
6. 可根据切削材料不同, 调整刀尖锋利程度, 提升铣刀寿命和切削效率、加工精度。

1. Applicable to (2\3\4-flute) tungsten carbide and high-speed steel end mill.
2. Grind rear inclined angle, blade edge and front inclined angle.
3. For different end mill grinding, no need to change grinding wheel.
4. Easy to handle, grind one piece need no more than one minute.
5. High precision(0.01mm), normatively re-sharpening.
6. Mill cutting edge can be adjusted suitable for materials to be processed.

设备参数 Product Parameter

型号 Model	适用铣刀直径 Applicable diameters	适用铣刀刃数 Applicable flutes	铣刀底刃研磨角度 Axial angles	砂轮 Grinding wheel	电源 Power	马达输出功率 Motor output	转速 Rated speed	设备外型尺寸 Outer dimensions	设备重量 Weight	标准附件 Normal accessories
ERM-12 ERM-12H (带精磨with fine grinding)	φ 2~ φ 12mm	2刃、3刃、4刃 2flutes、3flutes、4flutes	刀刃角6° Secondary clearance angle 6° 前斜角20° Primary relief angle 20° 后斜角30° End gash angle 30°	E12SDC (CBN选购Choose)	220V±10%AC	300W	6000 rpm	290x 260 x 230(mm)	15KG	夹套 7 个, 2 刃夹套固定套 8 个, 3 刃夹套固定套 8 个, 4 刃夹套固定套 8 个, 工具箱 1 个, 六角扳手 2 支, 控制器 1 个 Collet*7pcs, 2 flutes holder*8pcs, 3 flutes holder*8pcs, 4 flutes holder*8pcs, case*1pcs, Hexagon wrench*2pcs, controller*1pcs
ERM-12A	φ 2~ φ 12mm	2刃、3刃、4刃 2flutes、3flutes、4flutes	刀刃角8° Secondary clearance angle 8° 前斜角22° Primary relief angle 22° 后斜角30° End gash angle 30°	E12SDC-A (CBN选购Choose)	220V±10%AC	300W	6000 rpm	290x 260 x 230(mm)	15KG	夹套 7 个, 2 刃夹套固定套 8 个, 3 刃夹套固定套 8 个, 4 刃夹套固定套 8 个, 工具箱 1 个, 六角扳手 2 支, 专用夹套 1 只, 控制器 1 个, 垫圈 6 个 Collet*7pcs, 2 flutes holder*8pcs, 3 flutes holder*8pcs, 4 flutes holder*8pcs, case*1pcs, Hexagon wrench*2pcs, flutes holder*1pcs controller*1pcs Gaskets*6pcs, square
ERM-20 ERM-20H (带精磨with fine grinding)	φ 4 ~ φ 20mm	2刃、3刃、4刃 2flutes、3flutes、4flutes	刀刃角6° Secondary clearance angle 6° 前斜角20° Primary relief angle 20° 后斜角30° End gash angle 30°	E20SDC (CBN选购Choose)	220V±10%AC	600W	6000 rpm	310x 260 x 260(mm)	22KG	夹套 8 个, 2 刃夹套固定套 8 个, 3 刃夹套固定套 8 个, 4 刃夹套固定套 8 个, 工具箱 1 个, 六角扳手 2 支, 控制器 1 个 Collet*8pcs, 2 flutes holder*8pcs, 3 flutes holder*8pcs, 4 flutes holder*8pcs, case*1pcs, Hexagon wrench*2pcs, controller*1pcs
ERM-32	φ 12~ φ 32mm	2刃、3刃、4刃 2flutes、3flutes、4flutes	刀刃角6° Secondary clearance angle 6° 前斜角20° Primary relief angle 20° 后斜角30° End gash angle 30°	E32SDC (CBN选购Choose)	220V±10%AC	600W	6000 rpm	430x 350 x 330(mm)	40KG	夹套 5 个, 2 刃夹套固定套 5 个, 3 刃夹套固定套 5 个, 4 刃夹套固定套 5 个, 工具箱 1 个, 六角扳手 2 支, 控制器 1 个 Collet*5pcs, 2 flutes holder*5pcs, 3 flutes holder*5pcs, 4 flutes holder*5pcs, case*1pcs, Hexagon wrench*2pcs, controller*1pcs

铣刀研磨机系列 End mill Re-sharpening Machine

型号Model:
ERM-12H/20H



增加功能及特点

• ADDED FUNCTIONS AND FEATURES •

1. 研磨后的刀具, 提高了加工后的零件的表面光洁度。
 2. 1片砂轮即可实现铣刀的粗、精磨。
1. Tools after grinding, increased the surface finish of the parts after processing.
2. 1 grinding wheel can realize the coarse and fine grinding of the milling cutter.

产品升级, 增加铣刀精磨功能
Product upgrade, increase the fine grinding function of the milling cutter

型号Model:
ERM-12A



增加功能及特点

• ADDED FUNCTIONS AND FEATURES •

1. 可用钨钢棒料直接开出刃口进行粗加工, 节约刀具。
 2. 刀刃的刃倾角为8度, 适合直接在零件表面进行深槽加工;
1. Tungsten carbide bars can be grinded, and used as end mill.
2. The blade dip angle is 8° ,which is suitable for deep grooves processing.

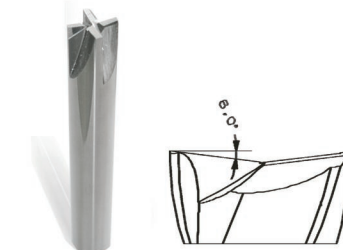

铣刀研磨机系列 End mill Re-sharpening Machine

型号Model:
ERM-12s/20s



砂轮说明:

SDC砂轮专用于研磨硬质合金刀具, CBN砂轮专用于研磨高速钢刀具

Grinding wheel: SDC wheels used for tungsten carbide tools, CBN wheels used for high-speed steel tools.

产品功能及特点 PRODUCT ADVANTAGES

1. 可研磨2刃、3刃、4刃硬质合金及高速钢端铣刀;
2. 研磨铣刀部位为刀刃角、前斜角和后斜角;
3. 一片砂轮即可完成不同刃数、不同直径的铣刀研磨;
4. 操作方便, 任何人都能在1分钟内完成研磨;
5. 研磨后铣刀标准和新刀保持一致, 刀刃等高精度在0.01mm以内;
6. 可根据切削材料不同, 调整刀尖锋利程度, 提升铣刀寿命和切削效率、加工精度。

1. Applicable to (2/3/4-flute) tungsten carbide and high-speed steel end mill.
2. Grind rear inclined angle, blade edge and front inclined angle.
3. For different end mill grinding, no need to change grinding wheel.
4. Easy to handle, grind one piece need no more than one minute.
5. High precision(0.01mm), normatively re-sharpening.
6. Mill cutting edge can be adjusted suitable for materials to be processed.

设备参数 Product Parameter

型号 Model	ERM-12S	ERM-20S
适用铣刀直径 Applicable diameters	φ3~φ12mm	φ4~φ20mm
适用铣刀刃数 Applicable flutes	2刃、3刃、4刃 2flutes、3flutes、4flutes	
铣刀底刃研磨角度 Axial angles	刀刃角6° Secondary clearance angle 6° 前斜角20° Primary relief angle 20° 后斜角30° End gash angle 30°	
砂轮 Grinding wheel	E12SDC (CBN选购Choose)	E20SDC (CBN选购Choose)
马达输出功率 Motor output	220V/300W	220V/600W
设备重量 Weight	13KG	16KG
标准附件 Normal accessories	夹套7个, 2刃夹套固定套3个, 3刃夹套固定套3个, 4刃夹套固定套3个, 工具箱1个, 六角扳手2支, 控制器1个 Collet*7pcs, 2 flutes holder*3pcs, 3 flutes holder*3pcs, 4 flutes holder*3pcs, case*1pcs, Hexagon wrench*2pcs, controller*1pcs	夹套8个, 2刃夹套固定套3个, 3刃夹套固定套3个, 4刃夹套固定套3个, 工具箱1个, 六角扳手2支, 控制器1个 Collet*8pcs, 2 flutes holder*3pcs, 3 flutes holder*3pcs, 4 flutes holder*3pcs, case*1pcs, Hexagon wrench*2pcs, controller*1pcs

球头铣刀研磨机 Ball end mill Re-sharpening Machine

型号Model:
BRM-13(R1-R6)



发明专利号: 201310160108.2
Patent for invention NO.



产品功能及特点 PRODUCT ADVANTAGES

1. 可研磨Φ2-Φ13的2刃硬质合金及高速钢球头铣刀;
2. 研磨铣刀部位为两个圆弧切削刃、后斜角、避空面;
3. 操作简单, 任何人都能在2分钟内完成研磨;
4. 研磨后刀具标准和新刀保持一致, 精度在0.02mm以内, 尺寸和精度完全由机器保证;
5. 可用钨钢棒直接研磨成球头铣刀进行加工;
6. 全球首创, 已申请发明专利。

1. Applicable to Φ2-Φ13 (2-flute) tungsten carbide and high-speed steel ball end mill.
2. Grind rear inclined angle, arc blade edge and front inclined angle.
3. Easy to handle, grind one piece need no more than 2 minute.
4. High precision(0.02mm), normatively re-sharpening.
5. Tungsten carbide bars can be grinded, and used as ball end mill.
6. Second to none, has applied for patent of invention.

设备参数 Product Parameter

型号 Model	BRM-13
适用球刀范围 Applicable range	R1~R6
适用球刀刃数 Applicable flutes	2刃 Two flutes
砂轮 Grinding wheel	B13SDC
电源 Power	220V ± 10% AC
马达输出功率 Motor output	250W
转速 Rated speed	2800 rpm
设备外型尺寸 Outer dimensions	580X570X400(mm)
设备重量 Weight	88KG
标准附件 Normal accessories	弹簧夹头7个, 直柄ER夹头刀柄1套, 工具箱1个, 六角扳手2支, ER-20A 扳手1个 Collet 7 pcs, ER collect handle 1 pcs, Tool case 1 pcs, Hexagon wrench 2 pcs, ER-20A wrench*1pcs



钻头研磨机系列 Drill Re-sharpening Machine

型号Model:
DRM-20S(Φ3-Φ20)

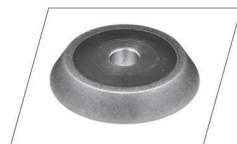

砂轮说明:
SDC砂轮专用于研磨硬质合金刀具, CBN
砂轮专用于研磨高速钢刀具
Grinding wheel: SDC wheels used for
tungsten carbide tools, CBN wheels used
for high-speed steel tools.



产品功能及特点 PRODUCT ADVANTAGES

- 1.可研磨直柄和锥柄标准麻花钻头;
 - 2.可研磨硬质合金及高速钢麻花钻头;
 - 3.研磨钻头长短不限;
 - 4.刃磨量可以调节设定.
 - 5.研磨出来的钻头, 呈抛物线形状, 加工切削更顺畅.
- 1.Can grind standard twist drill of direct shank and cone shank
 - 2.Applicable to tungsten carbide and high-speed steel drills re-sharpening.
 - 3.Length of drill to be grinded has no limitation.
 - 4.Can adjust and set edge grinding amount.
 - 5.After grinding, drill is parabolic shape, processing and cutting are more smooth

快速锋利
FAST SPEED, SHARP



五合一钻头研磨机 Five unity Drill Re-sharpener

型号Model:
F1-20



发明专利号: 201410076010.3
Patent for invention NO.



产品功能及特点 PRODUCT ADVANTAGES

- 1.可研磨Φ3-Φ20的普通麻花钻, 也可以研磨中心钻;
- 2.可研磨Φ4-Φ20的沉孔钻;
- 3.可研磨Φ4-Φ20的薄板钻;
- 4.可研磨Φ4-Φ20的周氏麻花钻;
- 5.操作简单, 研磨后钻头中心点精准, 钻孔效率高, 使用寿命长.

Applicable to twist drills (Φ3-Φ20) and center drills re-sharpening.
Applicable to Φ4-Φ20 plate drills and counter bore drills re-sharpening.
Applicable to Φ4-Φ20 Zhou drills re-sharpening.
Easy to handle, High precision, normatively re-sharpening.

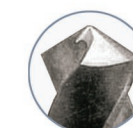

标准麻花钻
Twist drills

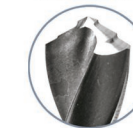

周氏麻花钻
Zhou drills



沉孔钻
Counter bore drills

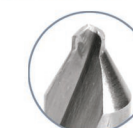

中心钻
Center drills

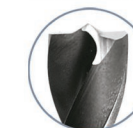

薄板钻
Plate drills

设备参数 Product Parameter

型号 Model	DRM-20S
适用直径 Applicable diameters	φ3~φ20mm
先端角(顶角)研磨范围 Grinding scope of the apex angle	90° ~140°
砂轮 Grinding wheel	D20CBN (SDC选购Choose)
马达输出功率 Motor output	250V/250W
设备重量 Weight	13KG
标准附件 Normal accessories	筒夹 φ3~φ20mm(18支),六角扳手2把,夹 头组1组,控制器1个 Collet φ3~φ20mm(18pcs), Hexagon wrench *2pcs, Chuck group *1 Group, controller*1pcs

设备参数 Product Parameter

型号 Model	F1-20			
研磨钻头类型 Applicable drill style	标准麻花钻 Twist drill	周氏麻花钻 Zhou drill	薄板钻 Plate drill	沉孔钻 Counter bore drill
适用钻头直径 Applicable range	Φ3~φ20	Φ4~φ20	φ4~φ20	φ4~φ20
先端角(顶角)范围 Apex angle	90° ~150°	90° ~150°	170° ~180°	170° ~180°
后角研磨范围 Dorsal horn	0° ~12°	0° ~12°	0° ~12°	0° ~12°
砂轮型号 Grinding wheel	D20CBN150	F1CBN150B1	F1CBN150B1	F1CBN150C1
电源 Power	220V + 10%AC			
马达输出功率 Motor output	250W			
转速 Rated speed	5000 rpm			
设备外型尺寸 Outer dimensions	350X160X180(mm)			
设备重量 Weight	20KG			
标准附件 Normal accessories	弹簧筒夹 φ3.5~φ20mm(18pcs)、六角扳手2.5mm*1pcs,5mm*1pcs、夹头组*2组、控制器1个 Collet φ3.5~φ20mm(18pcs),Grinding wheel 2pcs, Hexagon wrench 2.5mm*1pcs, 5mm*1pcs,Chuck group 2, Controller 1pcs			



钻头研磨机系列 Drill Re-sharpening Machine

型号Model:
DRM-13(Φ3-Φ13)
DRM-20(Φ3-Φ20)

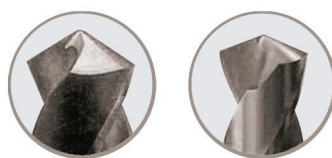

砂轮说明:
SDC砂轮专用于研磨硬质合金刀具, CBN
砂轮专用于研磨高速钢刀具
Grinding wheel: SDC wheels used for
tungsten carbide tools, CBN wheels used
for high-speed steel tools.

产品功能及特点 PRODUCT ADVANTAGES

- 1.可研磨硬质合金及高速钢麻花钻头;
- 2.研磨钻头部位为切削刃、横刃及后角;
- 3.操作简单, 任何人都能在20秒内完成研磨;
- 4.研磨后钻头中心点精准, 钻孔效率高, 使用寿命长;
- 5.可根据材料不同, 调节顶角角度(90°-150°)、后角角度(0°-12°)以及横刃宽度;
- 6.研磨钻头长短不限。

- 1.Applicable to tungsten carbide and high-speed steel drills re-sharpening.
- 2.Grind rear inclined angle, cutting edge and chisel edge.
- 3.Easy to handle, grind one piece need no more than 20 seconds.
- 4.High precision, normatively re-sharpening.
- 5.Apex angle can be adjusted from 90° to 150°, rear inclined angle from 0° to 12° according to materials to be processed.
- 6.Length of drill to be grinded has no limitation.



专利号(Patent NO.): ZL201220108696.6 ZL201220537851.6

钻头研磨机系列 Drill Re-sharpening Machine

型号Model:
DRM-50(Φ13-Φ50)



发明专利号: 201210400463.8
Patent for invention NO.

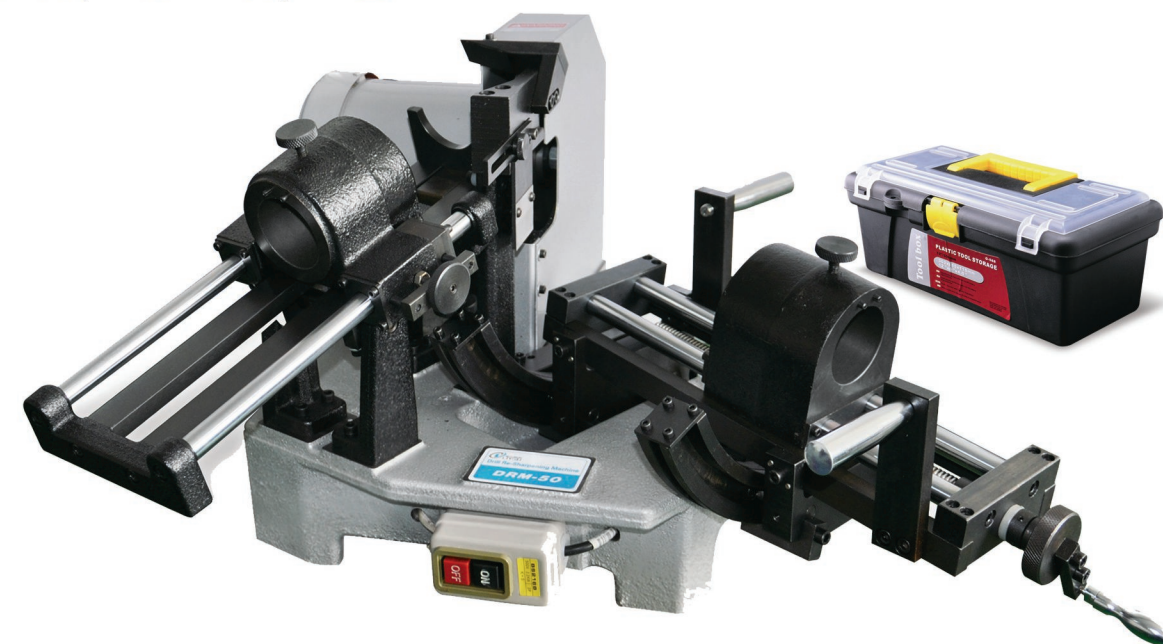
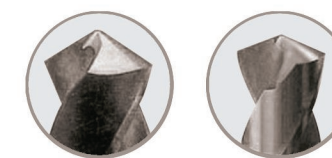

产品功能及特点 PRODUCT ADVANTAGES

- 1.可研磨Φ13-Φ50硬质合金及高速钢莫氏锥柄麻花钻头;
 - 2.研磨钻头部位为切削刃、横刃及后角;
 - 3.操作简单, 任何人都能在2分钟内完成研磨;
 - 4.研磨后钻头中心点精准, 钻孔效率高, 使用寿命长。
- 1.Applicable to Φ13-Φ50 tungsten carbide and high-speed steel drills re-sharpening, including Morse taper shank drills.
 - 2.Grind rear inclined angle, cutting edge and chisel edge.
 - 3.Easy to handle, grind one piece need no more than 2 minutes.
 - 4.High precision, normatively re-sharpening.



专利号(Patent NO.): ZL201220108695.1

型号 Model	适用钻头直径 Applicable diameter of the drill	先端角(顶角)研磨范围 Grinding scope of the apex angle	后角研磨范围 Grinding scope of the dorsal horn	砂轮 Grinding wheel	钻头长度 Length of drill	电源 Power	马达输出功率 Motor output	转速 Rated speed	设备外型尺寸 Outer dimensions	设备重量 Weight	标准附件 Normal accessories
DRM-13	Φ3~Φ13mm	90°~150°	0°~12°	D13CBN (SDC选购Choose)		220V±10%AC	250W	5000 rpm	290x260x230(mm)	16KG	筒夹Φ3~Φ13mm(11支),六角扳手2把,夹头组1组,控制器1个 Collet Φ3~Φ13mm(11 pcs), Hexagon wrench *2pcs, Chuck group* 1 Group, controller*1pcs
DRM-20	Φ3~Φ20mm	90°~150°	0°~12°	D20CBN (SDC选购Choose)		220V±10%AC	250W	5000 rpm	345x160x210(mm)	19KG	筒夹Φ3~Φ20mm(18支),六角扳手2把,夹头组2组,控制器1个 Collet Φ3~Φ20mm(18pcs), Hexagon wrench *2pcs, Chuck group* 2 Group, controller*1pcs
DRM-50	锥柄钻头 Φ13~Φ50mm Taper-shank drill Φ13~Φ50mm	118°~180°	4°	D50CBN	最大长度 400mm Maximum length 400mm	AC220V	200W	2800 rpm	650*590*350(mm)	68KG	变径套3支(4-1#,4-2#,4-3#) 楔铁3支 六角扳手2把 夹头组1组 Jacket for taper shank(4-1#,4-2#,4-3#) one for each, Iron wedge block*3pcs, Hexagon wrench *2pcs, Chuck group* 1 Group

倒角机系列 Chamfering Machine



CH500R-A



CH900-A

产品功能及特点 PRODUCT ADVANTAGES

1. 适合各类金属机械零部件的快速、顺滑倒角；
 2. 操作简单、可精确调整倒角部位尺寸，大幅提升倒角效率；
 3. CH500可倒直线C角，CH500R可倒直线C角及R角，CH900可实现直线和曲线（外部曲线和内孔曲线）倒C角；
 4. 装配标准钨钢刀片，更换方便，可调整切削点使刀片利用充分；
 5. 可选配滑动工作台，倒角时工作台滑动，避免划伤工件。
1. Applicable for metal parts chamfering.
 2. Easy to use, high efficiency, chamfering size can be adjusted accurately.
 3. CH500 applicable for chamfering C angle of line parts, CH500R applicable for C and R angle of line parts, CH900 applicable for C angle of line and curve parts.
 4. Equipped with standard blade, cutting point can be adjusted.
 5. Sliding workbench is available, so parts scratching can be avoided.

设备参数 Product Parameter

型号 Model	倒角尺寸 Chamfering size	电机 Motor	转速 Rotate speed	设备尺寸 Outer size	重量 Weight
CH500	0-4mm	220V/300W	5000-7000rpm	500*320*280mm	34KG
CH500R CH500R-A (带滑轨/with slide rail)	0-4mm, R2-R4mm	220V/300W	5000-7000rpm	500*320*280mm	34KG
CH900 CH900-A (带滑轨/with slide rail)	0-4mm	380V/750W	2800rpm	545*500*435mm	64KG

切断机 Cutting-off Machine

型号 Model	CM-25
切断范围 Cutting-off diameter	φ 3~φ 25mm
砂轮 Wheel	CM-SDC80# (钨钢铣刀、钻头专用 Tungsten steel cutter, drill dedicated) CM-CBN80# (HSS铣刀、钻头专用 HSS cutter, drill dedicated)
电源 Power supply	220V±10%AC
马达输出功率 Motor output	450W
转速 Rated speed	4500 rpm
设备重量 Weight	19KG
标准附件 Normal accessories	六角扳手1支、把手1支、电源线1根 Hexagon wrench*1pcs, Handle*1pcs, Power cord*1pcs



利优磨刀机为您带来的效益 what we can bring you

(以拥有3-5台加工中心为例)

节约项目 (月度) Savings	未使用利优磨刀机 Before using	使用利优磨刀机 After using
购买新刀的支出 Saving from buying new tools	(1万~1.5万)	(降低70%) 70 percent decreased
送到第三方研磨的支出 Saving from re-sharpening outside	(1500~2000)	0
磨刀师傅的工资 Saving from the salary of skilled grinding	(3000~8000)	0
磨刀师傅的培训费用 Saving from training grinding worker	()	0
因研磨精度差导致的产品报废费用 Saving from scrap decreased	(2000~3000)	0
因研磨精度差导致的订单延误或取消损失 Saving from delivery delay	()	0
合计 total 投资回收周期 (月) The payback period	(半个月~1个月)	投资回收期=购机支出 / (未使用前的刀具支出-使用后的刀具支出) The payback period=expense on machine/(expense on tools before using-expense on tools after using)

典型客户 Our Customers



利优精机—专利技术，缔造优秀品质！

Liyou precision machinery, patented technology, focusing on superior quality.

诚邀经销商加盟 DISTRIBUTOR WANTED!